

INTRODUCTION

Cathodeon manufactures a wide range of cool running xenon flash lamps, devices which efficiently convert electrical energy stored in a capacitor into a high intensity light flash.

Cathodeon xenon flash lamps consist of a compact bulb filled with xenon gas at a range of pressures. As xenon is a very good insulator, a high strike voltage is required to strike an arc, this is usually in the order of 5kV supplied by a separate trigger transformer.

All of the lamps use materials which are specially selected for high performance and long life. They are manufactured using high temperature and high vacuum processing, which ensures a high integrity product. Finally, each lamp is put through rigorous instrument test schedules to ensure that quality standards are consistently met.

Cathodeon offer three types of bulb xenon flash lamps of varying fill pressures and sizes. The technical differences of the differing lamps are outlined overleaf.

The main advantages common to all versions of bulb xenon flash lamps are:-

- **Low noise**
- **Excellent flash repeatability**
- **Long life**
- **Reliable starting when used with the appropriate Cathodeon trigger transformer**
- **Accurate arc position and discharge pattern**
- **Cool running**

Certain models of the Cathodeon range of xenon flash lamps may be filled alternatively with krypton and supplied with a range of windows.

WARNING - Flashes in the range of 1-10Hz may induce dangerous reactions in sensitive people.

SPECTRAL OUTPUT

Xenon lamps have a spectral distribution which ranges from the ultraviolet through the visible to the infrared, making them one of the few wide band illumination sources available. The spectral output, especially in the low UV, depends on the window material used. Spectral transmission ranges for available envelope/window materials are:-

- UV glass: 200 - 3500nm**
- Borosilicate glass: 300 - 4500nm**

Fig 1 Spectral Distribution

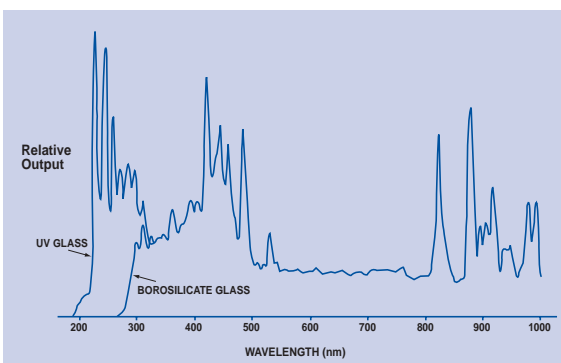

WINDOW MATERIAL

The windows of bulb lamps can either be made out of borosilicate glass or UV glass. The spectral transmission ranges for available envelope/window materials are given below:-

- UV glass: 200 - 3500nm**
- Borosilicate glass: 300 - 4500nm**

Fig 2 Window Transmission

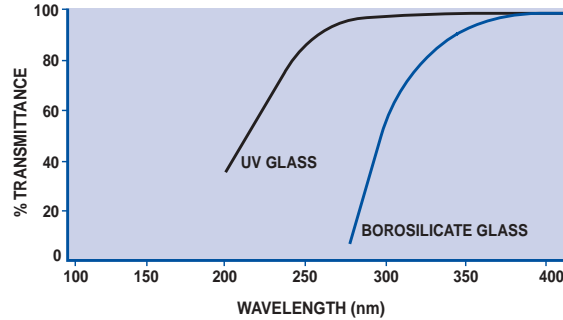

INTERNAL CONSTRUCTION

The electrodes are made of a tungsten matrix which contains barium, calcium and aluminium. The tungsten material carries the electrical load, whilst the other elements raise the efficiency of the cathode by lowering its work function. The electrodes can be either horizontally or vertically opposed with respect to the multi-pin lamp base, the position being dictated by the operating mode is either side output (S) or end output (E).

Xenon lamps are renowned for having unstable arcs, especially lamps with large electrode spacings where it is more likely that the arc will wander. For this reason, trigger electrodes are employed along the electrode gap to ensure optimum flash propagation when the specified voltage is applied across the electrodes. This voltage is applied to each trigger electrode in a timed sequence across the electrode gap, after the main discharge voltage is established between the anode and cathode. The arc position is established by the trigger discharges and therefore is more stable. The high striking voltage needed to initiate a discharge is also lowered by the action of these trigger electrodes.

Cathodeon trigger electrodes are unique in that they are positioned behind the electrode gap. This gives a straight arc as viewed through the window. Any degradation with time moves the arc only in the focal plane and not in a lateral position.

Also positioned in the bulb is a sparker, which is connected into the trigger circuit. The sparker flashes first, which then triggers the cathode and each consecutive trigger electrode. It provides UV light which releases photoelectrons from the cathode and trigger wires when it flashes, helping the main discharge to fire.

ARC LENGTHS

Cathodeon bulb type xenon flash lamps can be manufactured with any arc gap in the range 1.5mm to 10mm.

Experimentation on lamps with different arc gaps indicates that optimal arc stability, leading to high signal to noise ratios, is achieved with arc gaps in the 2.0mm to 5.0mm range. Lamps within this range, utilise two or three trigger electrodes to stabilise the arc across the gap, combining

XENON LAMPS

APPLICATIONS

Whilst xenon lamps are suitable for many white light industrial applications the high quality, high performance range of Cathodeon xenon lamps is expressly intended for photometric instrumentation applications such as:-

UV / visible spectrophotometry

Fluorescence spectroscopy

Liquid chromatography

Photo-acoustic spectroscopy

Colour analyzers

Medical instrumentation

These lamps will have many other potential uses in situations where controlled, repeatable, high intensity broadband illumination is desired.

XENON LAMPS

BULB TYPE XENON FLASH LAMPS

high performance with significantly improved lifetime. With arc gaps less than 2.0mm, the area of instability around the electrode where the arc joins the cathode is a large proportion of the total arc gap. In addition, it becomes almost a physical impossibility to fit more than one trigger electrode.

With arc lengths greater than 8.0mm the lamps are simply less efficient due to light collecting difficulties.

Sputtering of the electrodes occurs in lamps of all arc gaps due to the high currents involved. This sputtered material is distributed onto the envelope of the lamp, lowering the transmission and therefore the output. Lifetime is shortened through a combination of a darkened envelope and sputtered electrodes.

ENERGY OUTPUT

There are two limitations to the energy that can be dissipated in the lamps:-

1. The single pulse energy is limited by physical damage to the electrodes and the bulb, the energy is calculated by equation (i) $J = \frac{1}{2}CV^2$, where J is the energy per flash in Joules, C is the discharge capacitance in Farads and V is the charging Voltage.
2. The average dissipation energy is limited by thermal considerations equation (ii) $P = F \times J$, where P is the average power, F is the flash repetition frequency in Hertz and J is the energy per flash in Joules.

As can be seen, the power is directly proportional to the energy per flash (equation i) and the flash repetition frequency (equation ii). Using equations (i) and (ii), it can be seen that by increasing either the voltage or the discharge capacitance, the power can be increased. Increasing the voltage will have a more significant effect on power than if the discharge capacitance is increased, however increasing the voltage is limited by problems of insulation and arcing. If capacitance is used to increase the power, both rise time and pulse width increase. This greater pulse width will give rise to more local heating, hence there can be more rapid damage to the electrodes. With a high energy flash, the frequency can not be high as well. Therefore a choice has to be made whether to have a very bright flash at a low frequency or have a dimmer flash at a higher frequency.

REPETITION RATE

Cathodeon provides two types of flash lamp power supply which provide either:-

- (a) Fixed 50Hz operation
- (b) 50 - 100 Hz variable plus a switched external trigger input

The major consideration for repetition rate is that lamp life decreases more rapidly with increasing frequency and/or power input. Bulb lamps will run optimally even with single-shot operation, due to the internal triggering system.

Although lamps will theoretically run up to 1KHz or more (assuming power levels are kept within the specified limits from equations i & ii), it is difficult to ensure reliable operation at these frequencies, so it is advisable to contact Cathodeon regarding any operation above our standard maximum of 100Hz.

The main problems at higher frequencies are:-

- (a) Loss of voltage due to charging time in DC charging systems
- (b) Hold-on, where the lamps goes into DC conduction rapidly destroying itself and/or the power supply
- (c) Localised heating of electrodes and trigger wires which may shorten life

PULSE WIDTH

Half-height pulse widths are usually in the range of 2-5 μ S for the normal range of lamp operation. Changes of capacitor or voltage values have an effect on this parameter, in addition, changes in inductance in the system will alter the time constant and thus the discharge time. The higher the capacitance the longer the pulse.

Fig 3 Pulse Width

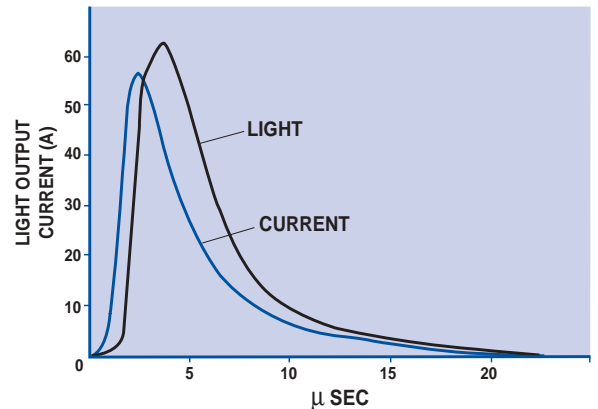

APPLICATIONS

There are two limitations to the energy that can be dissipated in the lamps:-

1. The single pulse energy where $J = \frac{1}{2}CV^2$

2. The average dissipation energy where $P = F \times J$

hi-Tech lamps

800-229-6509

info@hi-techlamps.com

LAMP SELECTION

This section gives background information, optimum operating conditions and specifications for the Cathodeon range of bulb type xenon flash lamps. The BX range are standard output small bulb xenon lamps for use with a separate trigger transformer. The AX range are high output small bulb xenon lamps for use with a separate trigger transformer and include the EX range extended envelope lamp. The FX range are high output large bulb xenon lamps.

BX RANGE

The BX range consists of small bulb Xenon lamps available with end emitting, or side emitting output. The lamps are designed to run optimally with the separate Cathodeon trigger transformer.

Both end and side output lamps are available with a choice of arc lengths, 2.0mm and 5.0mm. There is a window/envelope choice of either UV transmitting glass (U) or borosilicate glass (B)

Cathodeon recommends a maximum repetition frequency for this lamp of 100Hz. The lamp will operate at much higher frequencies than this, but great care is needed in the power supply to avoid overrunning the lamp. It is advisable to operate the lamp, where possible, at line frequency (50 or 60Hz) to avoid beat effects between the lamp and the mains.

AX (EX) RANGE

The AX range consists of a small bulb lamp filled to a higher pressure than the BX range and is available with end emitting or side emitting output. These higher pressure lamps offer increased light output by a factor of 1.7 over the standard BX lamps for the same power input. They offer low noise, excellent flash repeatability (<2%) and a long lifetime of at least 10^9 flashes depending on operating conditions. The lamp is hard soldered onto the circuit board to ensure the contact resistance is minimised, in view of the higher currents used in these lamps. It is possible to use these lamps with a separate trigger transformer, however, extreme care should be taken in the choice and integrity of the electrical pin to socket contact.

Also available is an extended version of the AX type, known as the EX lamp. As the bulb is extended by an extra 10mm the life of this lamp is much improved due to less sputtered material reaching the window, at the expense of a reduced solid angle. Especially suitable for industrial applications this lamp can last as long as 20,000 hours under optimal running conditions.

FX RANGE

The FX lamps use a larger envelope filled to a high pressure, combining both increased light output with improved lifetime by increasing the space between the arc and the window. The lamps are available with an arc length of 5.0mm, and a window choice of either UV transmitting glass (U), or Borosilicate glass (B).

The lamp is hard soldered onto the circuit board to ensure the contact resistance is minimised, in view of the higher currents used in these lamps.

A ten times increase in output over the standard bulb lamp, combined with a negligible effect on lifetime, means that the FX series lamps are ideal for replacing traditional compact arc lamps in applications where cool running and high arc stability are essential. The level of light available during the flash is roughly equivalent to a 400W CW lamp.

The FX series lamps are capable of operating up to 2kHz, however the Cathodeon C564 power supply permits operation up to 100Hz.

Fig 4a BXE Series Lamp 'End Emitting'

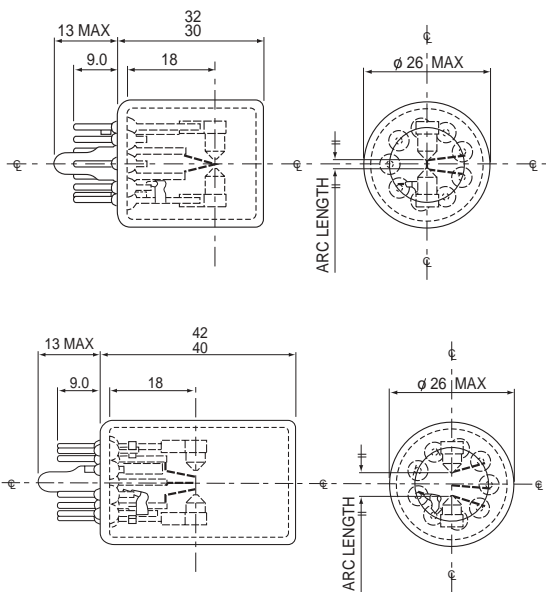

Fig 4c EXE Series Lamp 'End Emitting'

Fig 4b AXE Series Lamp 'End Emitting'

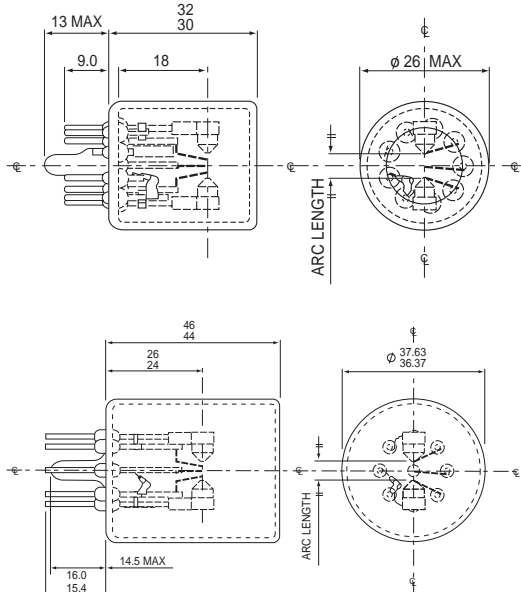

Fig 4d FXE Series Lamp 'End Emitting'

XENON LAMPS

APPLICATIONS

Whilst xenon lamps are suitable for many white light industrial applications the high quality, high performance range of Cathodeon xenon lamps is expressly intended for photometric instrumentation applications such as:-

UV / visible spectrophotometry

Fluorescence spectroscopy

Liquid chromatography

Photo-acoustic spectroscopy

Colour analyzers

Medical instrumentation

These lamps will have many other potential uses in situations where controlled, repeatable, high intensity broadband illumination

is desired.

BULB TYPE XENON FLASH LAMPS

XENON
LAMPS

OPTIMUM OPERATING CONDITIONS

	BX RANGE	AX RANGE	FX RANGE
Discharge capacitor	0.47 μ F	1 μ F	1 μ F
Charging voltage	600V	800V	600-1200V
Flash repetition frequency	50Hz	50Hz	100Hz

SPECIFICATIONS

	BX RANGE	AX RANGE	FX RANGE
Cooling	Not required	Not required	Not required
Bulb temperature	100°C	135°C	150°C
Anode voltage operating range	400-1000V DC	600-1000V DC	600-1200V DC
Trigger voltage	5kV (minimum)	5kV (minimum)	5kV (minimum)
Maximum average power	7W	16W	25W
Maximum energy per flash	0.15J	0.32J	2J
Maximum repetition frequency	100Hz	100Hz	200Hz ⁽ⁱⁱⁱ⁾
Light output stability	2% max fluctuation	2% max fluctuation	2% max fluctuation
Light pulse time jitter	200nSec maximum	200nSec maximum	200nSec maximum
Life expectancy	Up to 10 ⁹ flashes ⁽ⁱ⁾	Up to 10 ⁹ flashes ⁽ⁱ⁾	Up to 10 ⁹ flashes ⁽ⁱ⁾
Light pulse width	1-5 μ S ⁽ⁱⁱ⁾	1-5 μ S ⁽ⁱⁱ⁾	1-5 μ S ⁽ⁱⁱ⁾

NOTES

- (i) Dependent on operating conditions and wavelength
(ii) At half pulse height dependent on operating conditions
(iii) This value can be increased to 2000Hz if power is limited to 15W

ORDERING CODES

SERIES	ARC LENGTH	LAMP DESIGNATION		ORDERING CODE
		WINDOW	EMISSION	
BX SERIES	2.00 mm	UV transmitting glass	End emitting	BXE 2 U
			Side emitting	BXS 2 U
		Borosilicate glass	End emitting	BXE 2 B
			Side emitting	BXS 2 B
	5.00 mm	UV transmitting glass	End emitting	BXE 5 U
			Side emitting	BXS 5 U
		Borosilicate glass	End emitting	BXE 5 B
			Side emitting	BXS 5 B
AX SERIES	2.00 mm	UV transmitting glass	End emitting	AXE 2 U
			Side emitting	AXS 2 U
		Borosilicate glass	End emitting	AXE 2 B
			Side emitting	AXS 2 B
	5.00 mm	UV transmitting glass	End emitting	AXE 5 U
			Side emitting	AXS 5 U
		Borosilicate glass	End emitting	AXE 5 B
			Side emitting	AXS 5 B
EX SERIES	2.00 mm	UV transmitting glass	End emitting	EXE 2 U
		Borosilicate glass	End emitting	EXE 2 B
	5.00 mm	UV transmitting glass	End emitting	EXE 5 U
		Borosilicate glass	End emitting	EXE 5 B
FX SERIES	5.00 mm	UV transmitting glass	End emitting	FXE 5 U
			Side emitting	FXS 5 U
		Borosilicate glass	End emitting	FXE 5 B
			Side emitting	FXS 5 B

APPLICATIONS

The C564 B2 is a variable frequency board form power supply suitable for use with the complete range of Cathodeon pulsed xenon lamp range. It allows the flash rate to be set within the limits of 1Hz to 100Hz.

POWER SUPPLY FOR XENON FLASH LAMPS

TYPE C564 B2

The C564 B2 is a variable frequency board form power supply suitable for use with the complete range of Cathodeon pulsed xenon lamp range. It allows the flash rate to be set within the limits of 1Hz to 100Hz. The supply is normally set at the factory to cover a smaller range e.g. 1 octave of frequency. This enables a higher pulse output power to be chosen than would be allowed if the full frequency range was made available. The maximum pulse power is set at the factory to suit the individual customer requirements and lamp type. This power supply has an external drive facility and when this is to be used customers are warned not to exceed the lamp power rating. The power supply itself is self limiting so cannot be damaged by driving at too high a frequency.

Hi-Tech lamps

800-229-6509

info@hi-techlamps.com

SPECIFICATIONS

Lamp Supply Voltage 850V

Anode Capacitor Chosen to suit frequency range to be used

Output Pulse length 1 μ S to 20 μ S.
Dependent on discharge capacitor size

Peak Current Up to 500A

Repetition Rate 1-100 Hz

Power Max average power 25W
Peak pulse power 2.0J
Lamp Trigger Pulse 5KV min

Input Trigger 5V TTL internal adjustment for positive or negative edge synchronisation
BNC socket on front panel

Lamp Connections Via multipin connector on rear panel

Input Requirements 110, 130, 220, 240V (\pm 10%rms)
50/60Hz

Dimensions Mains transformer
120mm x 105mm x 100mm high
Weight: 4.35kg

Circuit Control Unit
150mm x 110mm x 40mm high
Weight: 0.215kg

XENON LAMPS

APPLICATIONS

Whilst xenon lamps are suitable for many white light industrial applications the high quality, high performance range of Cathodeon xenon lamps is expressly intended for photometric instrumentation applications such as:-

UV / visible spectrophotometry

Fluorescence spectroscopy

Liquid chromatography

Photo-acoustic spectroscopy

Colour analyzers

Medical instrumentation

These lamps will have many other potential uses in situations where controlled, repeatable, high intensity broadband illumination is desired.

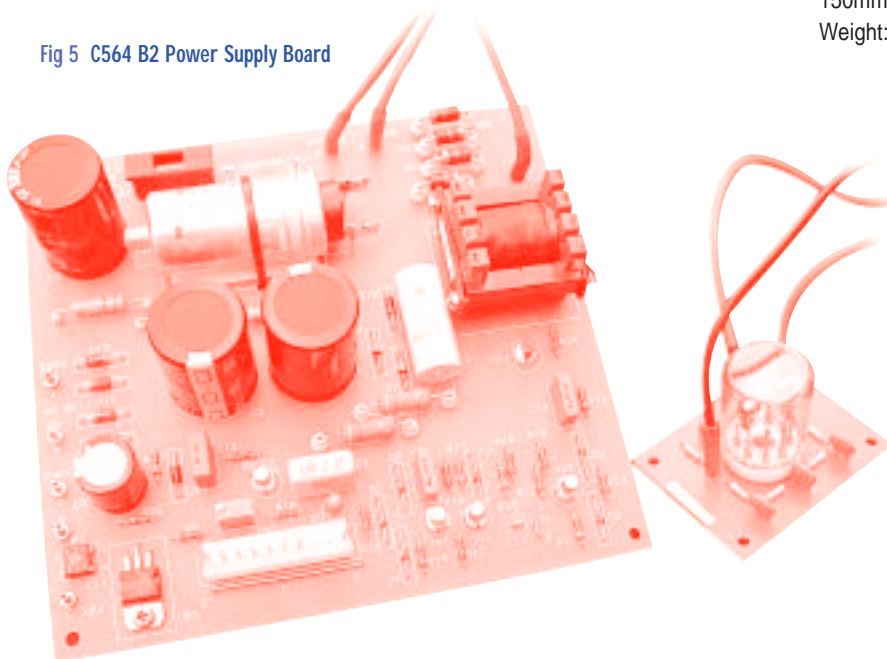

Fig 5 C564 B2 Power Supply Board

ORDERING CODES

POWER SUPPLY

Variable frequency board from pulsed xenon lamp power supply

ORDERING CODE

C564 B2

CONTINUOUS SHORT ARC XENON LAMP

XENON LAMPS

INTRODUCTION

Cathodeon offers a range of continuous xenon lamps, from 50W to 7000W. These lamps can be used in many white light illumination applications, however these sources require bulky, complex power supplies and produce high levels of heat, rendering them unsuitable for many high sensitivity opto-electronic applications. Cathodeon does offer a stable long life 150W lamp specifically for instrumental applications.

The HSX 150 range is electrically compatible with all 150W lamps currently on the market so offering an excellent solution for applications requiring a xenon point source with high radiance, broad spectral output and high stability.

There are four different HSX lamps, with arc lengths of 2.0mm or 2.5mm, and arc tube material of either fused silica or ozone-free silica. They offer exceptional stability and have an average service life of 2000 hours with minimum arc shift over this period. Therefore they are especially suited to analytical instrumentation.

Fig 6 HSX Series Lamp

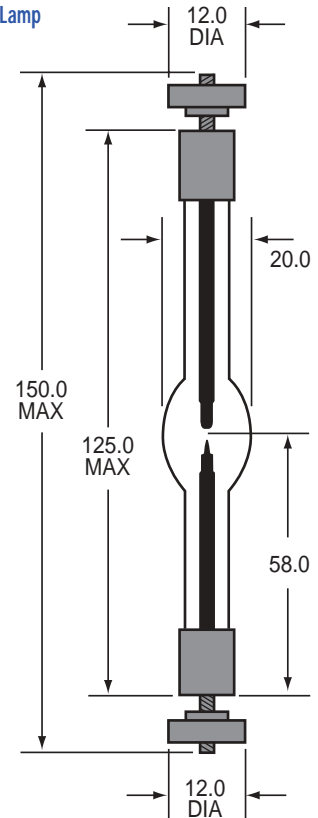

SPECIFICATIONS

PARAMETER	TYPE 1	TYPE 2	TYPE 3	TYPE 4
Operating power (W)	150	150	150	150
Arc tube material	Fused silica	Ozone fused silica	Fused silica	Ozone free silica
Arc gap (mm)	2.5	2.5	2.0	2.0
Voltage (V)	20 ± 2	20 ± 2	18 ± 2	18 ± 2
Current (A)	7.5 ± 0.5	7.5 ± 0.5	8.5 ± 0.5	8.5 ± 0.5
Ignition voltage (Nominal, kV)	25	25	25	25
Output (Nominal, Lumens)	2600	2600	2600	2600
Average Life (hours)	2000	2000	2000	2000

ORDERING CODES

LAMP TYPE	ORDERING CODE
Type 1	HSX150-1
Type 2	HSX150-2
Type 3	HSX150-3
Type 4	HSX150-4

APPLICATIONS

The HSX lamps with exceptional noise and stability performance are particularly suitable for challenging applications such as:-

Spectrophotometry

Fluorescence

Graphic arts

Microscope illumination

Solar simulation

Colour analyzers

Densitometers

hi-Tech lamps

800-229-6509

info@hi-techlamps.com