

## METAL ARC LAMPS

### EmArc®

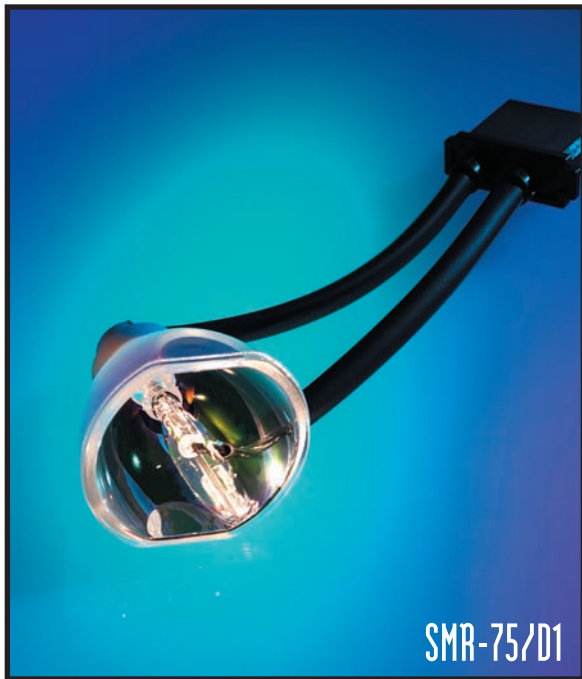

SMR-75/D1

### NEW SMR-75/D1 EmArc® ENHANCED METAL ARC LAMPS

For over 50 years USHIO has been developing advanced lighting technologies for the world. Now there is EmArc® 75W - a new and exciting advancement in the world of light. This 75W compact package has precise and powerful light.

EmArc® lighting technology is the culmination of a dedicated effort to bring together the inherent advantages of a number of gas discharge sources into a single light source.

EmArc® light sources are a series of highly efficient, Enhanced Metal Arc, DC gas discharge lamps designed for use in medical, scientific, industrial and entertainment settings. EmArc® lamps are a progressive step ahead in lighting technology possessing features that offer advantages to an array of users for imaging, fiber optic and other important optical applications.

EmArc® lamps have geometric designs which enable alignment in dichroic visible light or UV specific coated reflectors facilitating use in numerous applications like lighting for minimally invasive surgery,

curing of light sensitive resins and adhesives, and dental whitening procedures. EmArc® versatility enables its use in a number of entertainment applications including searchlights, followspots, special effects and automated fixtures.

EmArc® lamps are comparable to metal halide sources in luminous efficacy but with 2 times to 5 times the life. EmArc® lamps have very small arc gap sizes and have more than 2 times the luminous efficacy of xenon lamps.

EmArc® technology differentiates itself as a new family of discharge lamps.

## EmArc® DC arc discharge

The construction of EmArc® arc tubes, electrodes and precise filling technique provide the environment for the tightly confined plasma arc discharge. EmArc® lamp life exceeds that of typical DC xenon and AC short-arc metal halide lamps.

**hi-Tech lamps**

800-229-6509

info@hi-techlamps.com

High luminance at tip of cathode  
with DC arc discharge

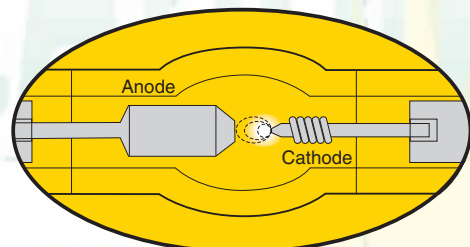

See **FEATURES & BENEFITS** on back

### EmArc® REFLECTORIZED VERSION

SMR-75/D1

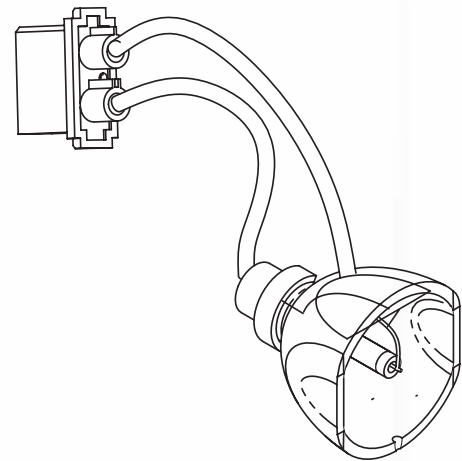
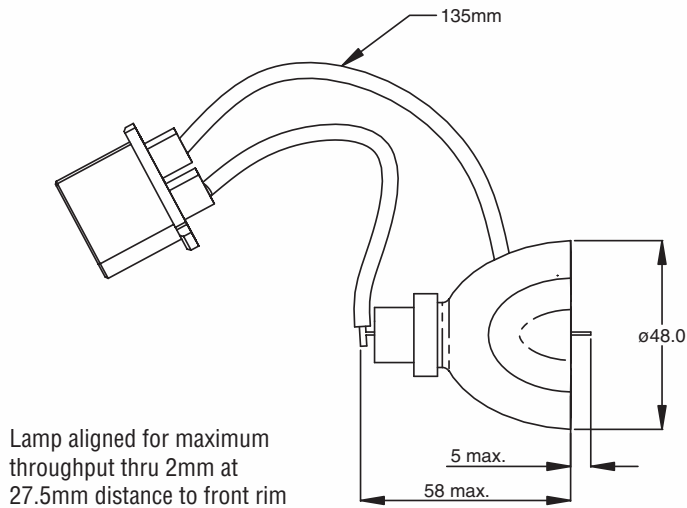

All dimensions are in millimeters

Ushio Ordering Code	Ushio Lamp Code	Wattage Power Range (W)	Lamp Current (A)	Arc Gap (mm)	Luminous Flux* (lm) nom	Avg Rated Life (h)	Color Temp* (K)
---------------------	-----------------	-------------------------	------------------	--------------	-------------------------	--------------------	-----------------

**REFLECTORIZED VERSION**

5002046	SMR-75/D1	50-75W	1.33 nom.	1.2	700	1000	8200 ± 500
---------	-----------	--------	-----------	-----	-----	------	------------

Lamp Voltage (V)	Maximum Allowable Starting Current	Ignition Voltage	Minimum Voltage After Start Up	Typical Warm Up Time
------------------	------------------------------------	------------------	--------------------------------	----------------------

55V DC (-8+12)	2.3A	25kV (for Hot Re-ignition)	10-15V DC	90 sec. nom.
----------------	------	----------------------------	-----------	--------------

\* Output and Correlated Color Temperature as measured through a 2mm aperture at 27.5mm from the reflector rim into a sphere. Actual values are dependent on the specific optical set-up used.

**hi-Tech lamps**

800-229-6509

info@hi-techlamps.com

### EmArc®

#### SMR-75/D1

### Hi-Tech lamps

800-229-6509

info@hi-techlamps.com

## APPLICATIONS

### FIBER OPTIC EFFICIENCY

Measured lumens vs. aperture size

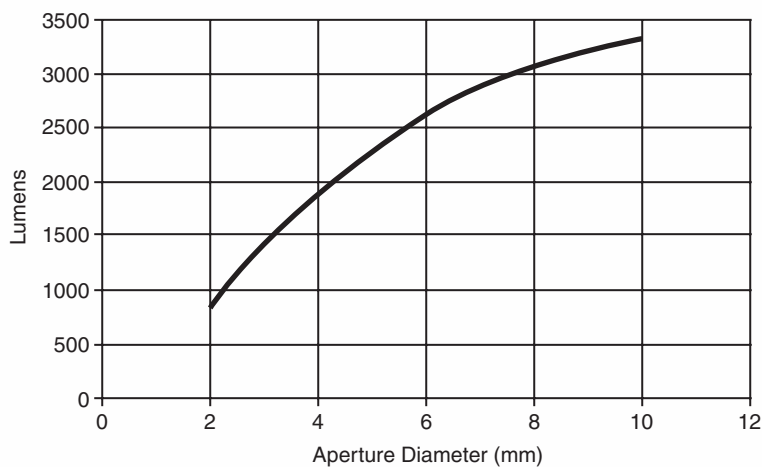

- Industrial fiber optics / Borescopy
- Dental / Surgical vision
- Medical fiber optics
- Bio-technology
- Machine vision
- Microscopy
- UV curing
- Analytical

### EmArc® SPECTRAL DISTRIBUTION

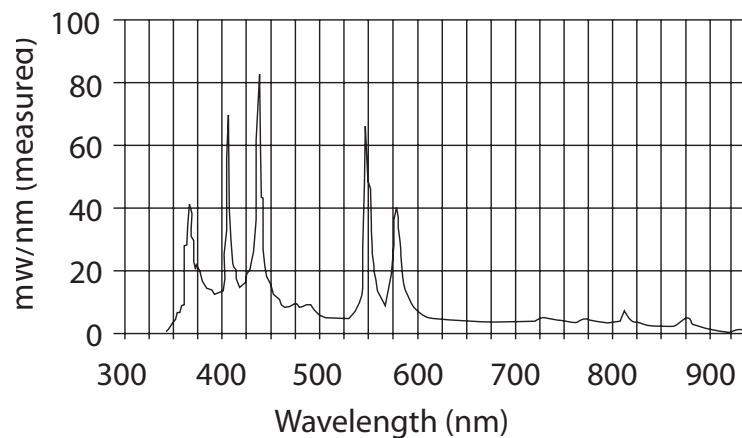

### EmArc®

#### ENHANCED METAL ARC TECHNOLOGY

### FEATURES & BENEFITS

- Power range from 50-75 watts—
  - Versatility/ power tunability
- Small arc gap size to 1.2mm—
  - Highly effective optical collection capability
- Unique hybrid gas discharge technology—
  - 1,000 hours of life provides staying power over other conventional gas discharge sources.
  - No high internal pressure when cold
- Special, rugged, compact, 48mm Ø elliptical reflector design—
  - Very high light path efficiencies for small diameter fiber-optic bundle applications
  - Highly durable
- Precise filling control, electrode design and tight manufacturing tolerances with tipless arc tube construction—
  - Tightly confined and stable plasma discharge, long life
  - Minimal color temperature drift over life
  - Better optical control, no shadowing
- EmArc® DC technology—
  - Enables operation on lower cost DC power supplies reducing OEM system design costs
- High correlated color temperature—
  - White light for crisp imaging
- Unique chemistry—
  - High efficacy nearly 2 times that of xenon sources
- USA engineered and manufactured—
  - Dependability, accessibility and flexibility
  - Development and engineering support close to the customer
- 1,000 hours of life—
  - 2 times to 4 times that of conventional AC short-arc metal halide or xenon sources
- EmArc® gas technology—
  - No heat sinks, less IR and thermal loads to work around. Less strain on components. Simpler system design issues.

### NEW UBX-76 ELECTRONIC POWER SUPPLY

#### SMARTARC™ SERIES NEW UBX-76 POWER SUPPLY

Operates Emarc® DC lamps in power ranges between 50W-75W

Find out more information about our NEW UBX-76 SMARTARC™ Power Supply by contacting your Regional Sales Manager.

#### UBX-76 SERIES



### Hi-Tech Lamps

800-229-6509

info@hi-techlamps.com